

STUDENT NAME: _____

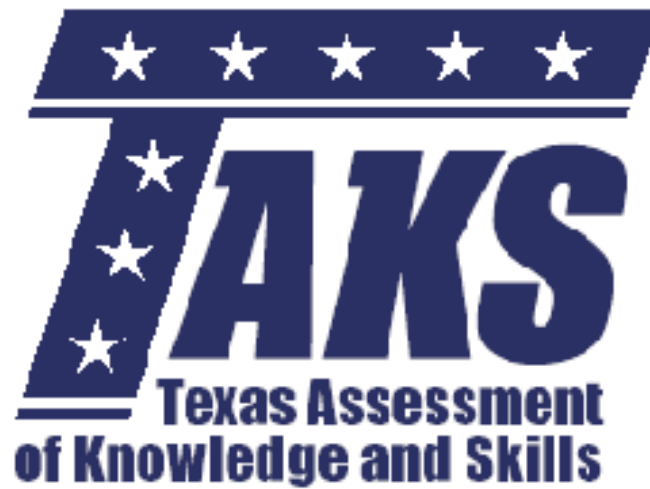

**GRADE 9
MATHEMATICS**

Administered October 2009



9th Grade TAKS Practice Test 1

- 1 A 12 by 16-foot rectangular floor will be covered by square tiles that measure 2 feet on each side. If the tiles are not cut, how many of them will be needed to cover the floor?

A 14
 B 96
 C 48
 D 192

- 2 On a certain day the exchange rate of Mexican pesos for U.S. dollars was approximately 10 pesos for 1 dollar. If an exchange of 4,000 pesos was made that day, what was the approximate value of the exchange in dollars?

F \$40,000
 G \$400
 H \$40
 J \$4,000

- 3 Which is always a correct conclusion about the quantities in the function $y = x + 4$?

A As the value of x increases, the value of y decreases.
 B The variable x is always 4 more than y .
 C When the value of x is negative, the value of y is also negative.
 D The variable y is always greater than x .

- 4 Jake made a map of his neighborhood for a school project. He placed a grid over the map.

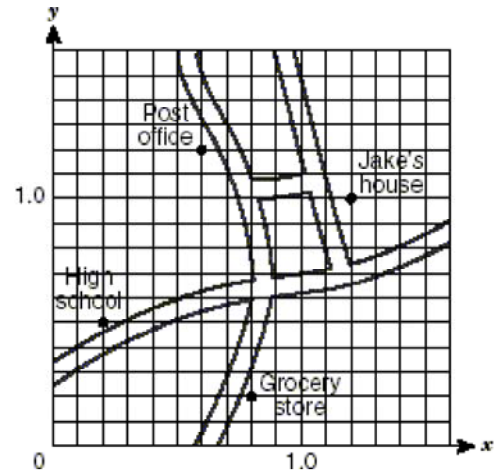

Which coordinate point best represents the post office?

F (0.6, 1.2)
 G (12, 6)
 H (6, 12)
 J (1.2, 0.6)

- 5 For a car traveling at a speed of 50 miles per hour, the relationship between the distance traveled, d , and the time traveled, t , is described by the function $d = 50t$. Which statement is true?

A The speed of the car depends on the time traveled.
 B The speed of the car depends on the distance traveled.
 C The distance traveled depends on the time traveled.
 D The time traveled depends on the distance traveled.

6 Which circle has a center located at coordinates $(-3, 2)$?

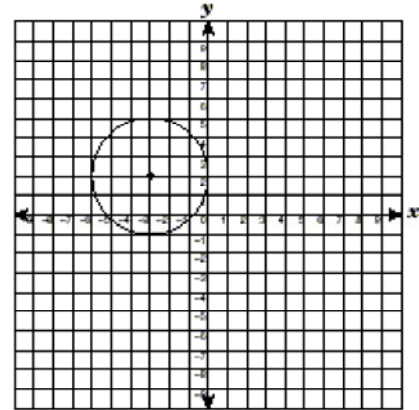
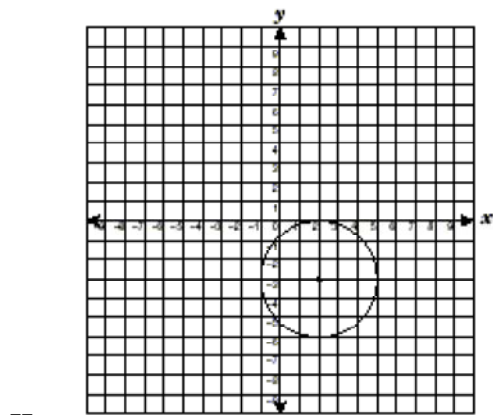
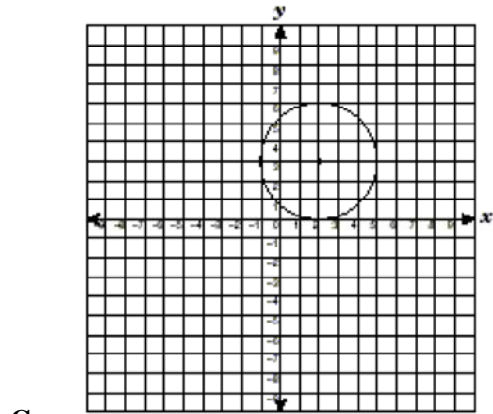
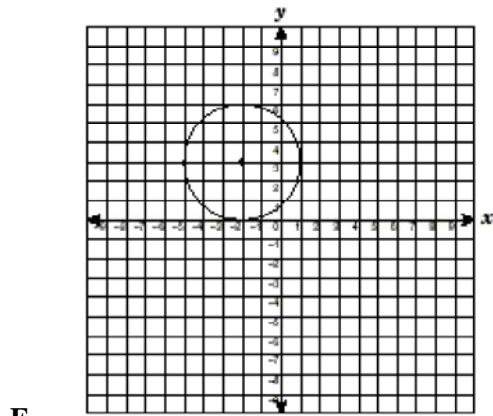

7 Which expression describes the area in square units of a rectangle that has a width of $4x^3y^2$ and a length of $3x^2y^3$?

- A $12x^5y^5$
- B $12x^6y^6$
- C $7x^5y^5$
- D $7x^6y^6$

8 Alonso's family rented a car when they flew to Orlando for a 4-day vacation. They paid \$39 per day and \$0.09 for each mile driven. How much did it cost to rent the car for 4 days and drive 350 miles, not including tax?

- F \$124.50
- G \$156.00
- H \$70.50
- J \$187.50

- 9 A newspaper reported that the mean height of waves in the Norwegian Sea increased by 4 inches per year from 1955 to 1994. What additional information is needed to calculate the mean wave height in 1994?
- A The mean height of waves in 1955
 - B The projection of the mean height of waves for the next year
 - C The distance from land to where the wave measurements were taken
 - D The range of wave heights from 1955 to 1994

- 10 When graphed, which function would appear to be shifted 2 units up from the graph of $f(x) = x^2 + 1$?

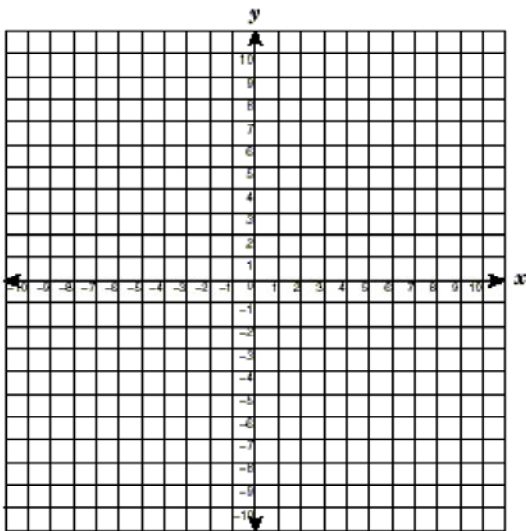

- F $g(x) = x^2 + 3$
- G $g(x) = x^2 + 2$
- H $g(x) = x^2 - 2$
- J $g(x) = x^2 - 1$

- 11 Ms. Kitts works at a music store. Last week she sold 6 more than 3 times the number of CDs that she sold this week. Ms. Kitts sold a total of 108 CDs over the 2 weeks. Which system of equations can be used to find l , the number of CDs she sold last week, and t , the number of CDs she sold this week?

- A $l + t = 108$
 $t = 3l - 6$
- B $l + t = 108$
 $t = 3l + 6$
- C $l + t = 108$
 $l = 3t + 6$
- D $l + t = 108$
 $l = 3t - 6$

- 12 Kate has 2 similar triangular pieces of paper, as shown below.

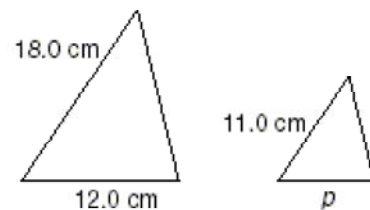

Using the dimensions given, find the approximate length of the side labeled p .

- F 16.5 centimeters
- G 2.4 centimeters
- H 19.6 centimeters
- J 7.3 centimeters

- 13 In a town, there is a small garden shaped like a triangle, as shown below. The side of the garden that faces Sixth Street is 80 feet in length. The side of the garden that faces Third Avenue is 30 feet in length.

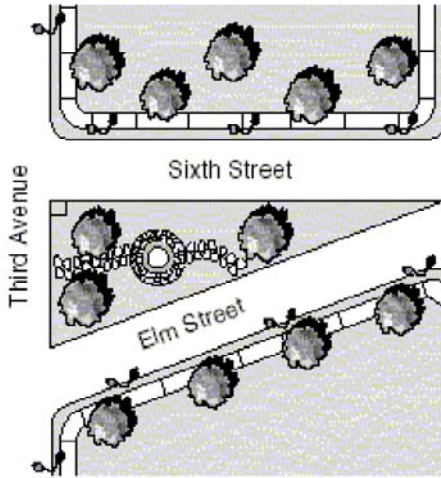

What is the approximate length of the side of the garden that faces Elm Street?

- A 85 ft
- B 40 ft
- C 110 ft
- D 35 ft

- 14 The function $f(x) = \{(1, 2), (2, 4), (3, 6), (4, 8)\}$ can be represented in several other ways. Which is NOT a correct representation of the function $f(x)$?

F x is a natural number less than 5 and y is twice x

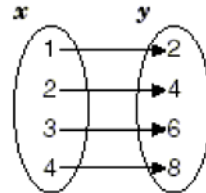

G

H $y = 2x$ and the domain is $\{1, 2, 3, 4\}$

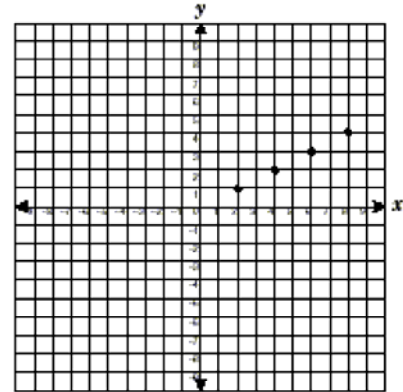

J

- 15 A math club decided to buy T-shirts for its members. A clothing company quoted the following prices for the T-shirts.

Math Club T-Shirts

Number of T-Shirts	Total Cost (dollars)
10	75
15	105
20	135

Which equation best describes the relationship between the total cost, c , and the number of T-shirts, s ?

- A $c = 7.00s$
 B $c = 6.75s$
 C $c = 2s - 20$
 D $c = 15 + 6s$
- 16 Trina was recording the calorie content of the food she ate. For lunch she had 3 ounces of chicken, 2 slices of cheese, 2 slices of wheat bread, one-half tablespoon of mayonnaise, a 16-ounce glass of lemonade, and an apple for dessert. According to the chart below, which equation best represents the total number of calories she consumed during lunch?

Calorie Content

Food	Calories
Apple (medium)	70
Wheat Bread (1 slice)	55
Cheese (1 slice)	45
Chicken (3 oz)	115
Lemonade (8 oz)	110
Mayonnaise (1 tbsp)	100

- F $\text{Calories} = 115 + \frac{45}{2} + \frac{55}{2} + 2(100) + \frac{110}{2} + 70$
 G $\text{Calories} = 115 + 2(45) + 2(55) + \frac{1}{2}(100) + 2(110) + 70$
 H $\text{Calories} = 115 + 45 + 55 + 100 + 110 + 70$
 J $\text{Calories} = 3(115) + 2(45) + 2(55) + \frac{1}{2}(100) + 16(110) + 70$

17 A couple bought a house and calculated that they would pay 30% of their combined monthly income of \$5,569.75 toward the monthly mortgage payment on the house. Approximately how much will the couple pay for their monthly mortgage payment?

- A \$186
- B \$18,566
- C \$3,899
- D \$1,671

18 Match the three views of this solid to its 3-dimensional sketch.

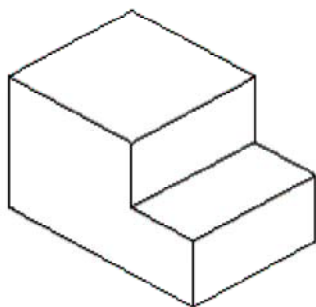

F

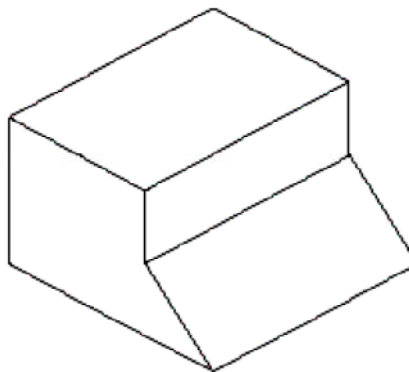

H

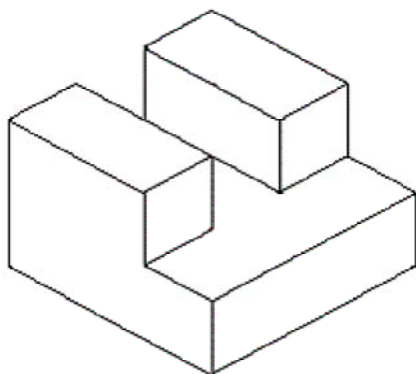

G

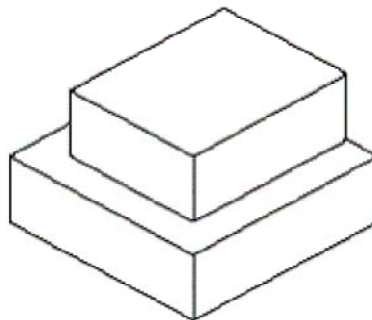

J

19 Last basketball season Ricky made 58% of the free throws he attempted. In the first game this season, Ricky went to the free-throw line 10 times. About how many free throws did Ricky make if his success rate from last season continued?

- A 10
- B 58
- C 6
- D 4

20 The graph of a line that contains the points $(-1, -5)$ and $(4, 5)$ is shown below.

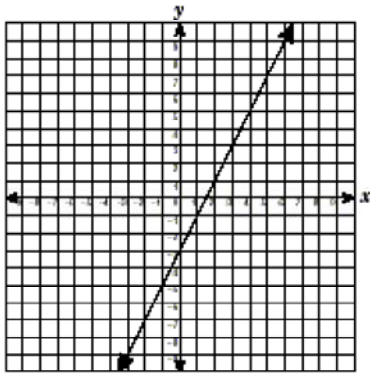

Which best represents this line if the slope is doubled and the y-intercept remains constant?

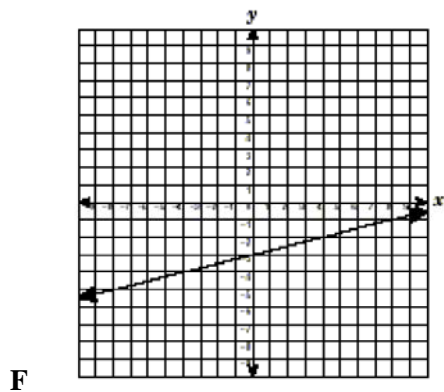

G

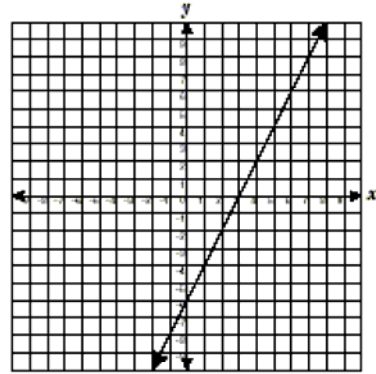

H

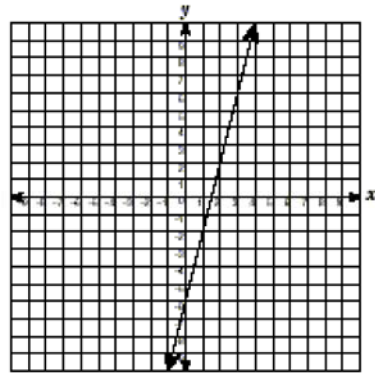

J

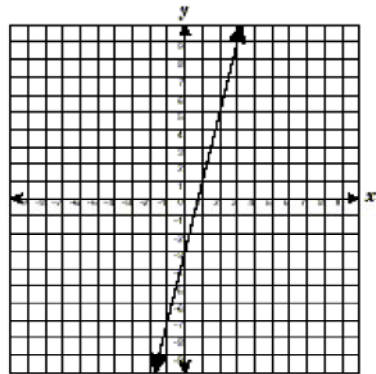

- 21 A store sells milk in two different containers. The first container is a rectangular prism that has a height of 8 inches and a square base with a side length of 2 inches. The other container is a cylinder with a radius of 1.75 inches and a height of 8 inches. Which best describes the relationship between the two containers?
- A The volumes cannot be determined.
 B The cylinder has the greater volume.
 C The volumes are equivalent.
 D The prism has the greater volume.
- 22 Which problem is best represented by the number sentence $19 + 3(12 - x) = 40$?
- F Denise paid \$19 for 1 regularly priced item and bought 3 items on sale that were regularly priced at \$12. She spent \$40 in all. What was the price reduction on the 3 sale items?
 G Juan earned \$19 baby-sitting and sold 3 boxes of apples for \$12 each. Now he has \$40. How much did he earn?
 H Ricardo spent \$19, and Lydia spent 3 times \$12 less than Ricardo. Together they spent \$40. How much did Lydia spend?
 J Gail earned \$19 baby-sitting and mowed 3 lawns in less than 12 hours. She earned a total of \$40. How much did she earn per lawn?
- 23 A watch loses 3 minutes every 24 hours. How much time will it lose in 2 hours?
- A 5 seconds
 B 1.6 seconds
 C 22.5 seconds
 D 15 seconds
- 24 The area of a rectangle is $30m^{11}n^5$ square units. If the length of the rectangle is $6m^4n^2$ units, how many units wide is the rectangle? ($m \neq 0$) and ($n \neq 0$)
- F $180m^{15}n^7$ units
 G $36m^{15}n^7$ units
 H $24m^7n^3$ units
 J $5m^7n^3$ units
- 25 Auto-Check Motors charged Mr. Jones \$84.00 for an automotive part plus \$68.00 per hour that a mechanic worked to install the part. The total charge was \$353.00. For about how long did the mechanic work to install the part on Mr. Jones's car?
- A 5 h
 B 4 h
 C 3 h
 D 6 h
- 26 The number of hours Abe practices golf each week, g , is 2 more than the number of hours he runs, r . Which equation represents the number of hours he runs each week?
- F $g = r - 2$
 G $g = 2r$
 H $r = g + 2$
 J $r = g - 2$
- 27 Describe the effect on the area of a circle when the radius is doubled
- A The area is increased four times.
 B The area is reduced by $\frac{1}{2}$.
 C The area is doubled.
 D The area remains constant.

28 Identify the graph that best represents the relationship between the number of gallons of gasoline Mr. Johnson purchased at \$1.49 a gallon and the total cost of his gasoline.

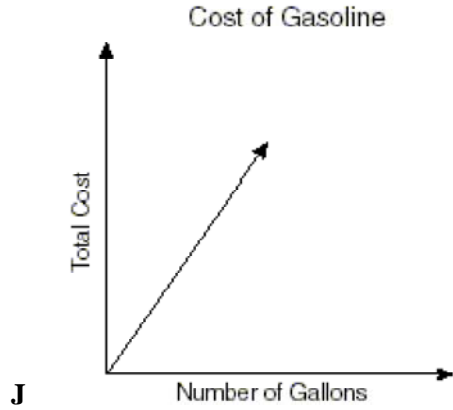
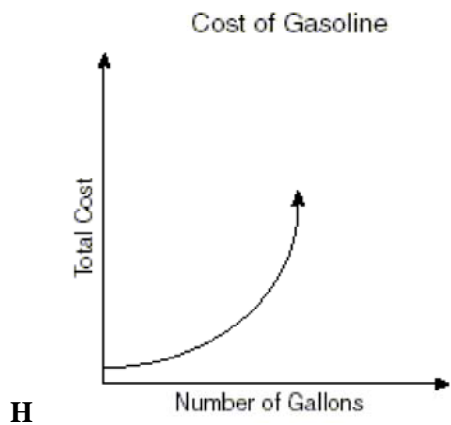
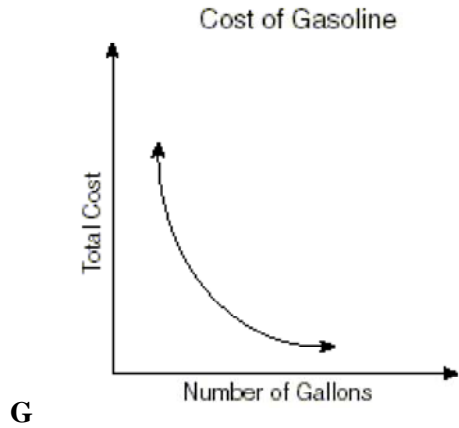
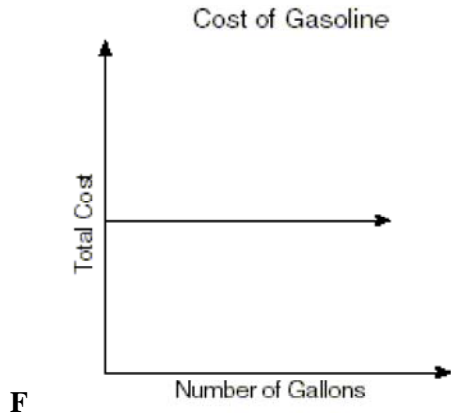

29 Triangle RST is shown on the coordinate plane below.

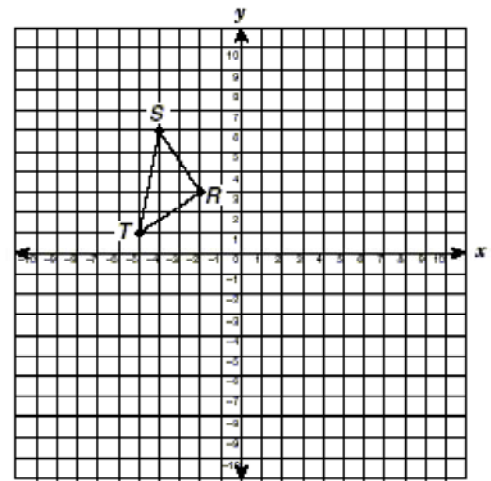

Find the coordinates of the vertices of the image of triangle RST reflected across the y-axis.

- A (2, 3), (4, 6), (5, 1)
- B (2, -3), (4, -6), (5, -1)
- C (0, 3), (-2, 6), (-3, 1)
- D (-2, -3), (-4, -6), (-5, -1)

- 30 A lawn is shaped like a parallelogram with a base of 30 inches and a height of 24 inches. Covering the lawn with grass will cost \$2.60 per square foot. How much money will it cost to cover the lawn with grass?

F 13
G 8
H 10
J 15

- 31 The net of a cylinder is shown below. Use the ruler on the Mathematics Chart to measure the dimensions of the cylinder to the nearest $\frac{1}{8}$ inch.

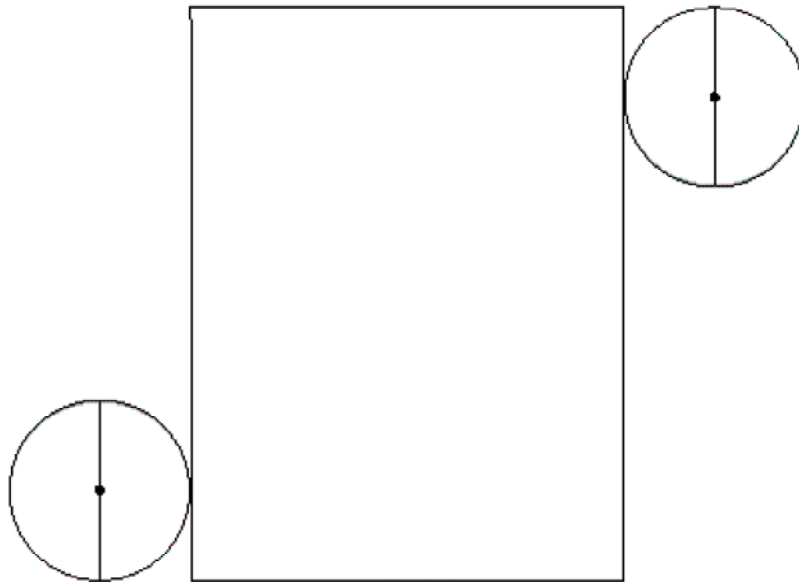

Which is closest to the total surface area of this cylinder?

A 11 in.²
B 4 in.²
C 25 in.²
D 14 in.²

- 32 Which linear function includes the points $(-3, 1)$ and $(-2, 4)$?

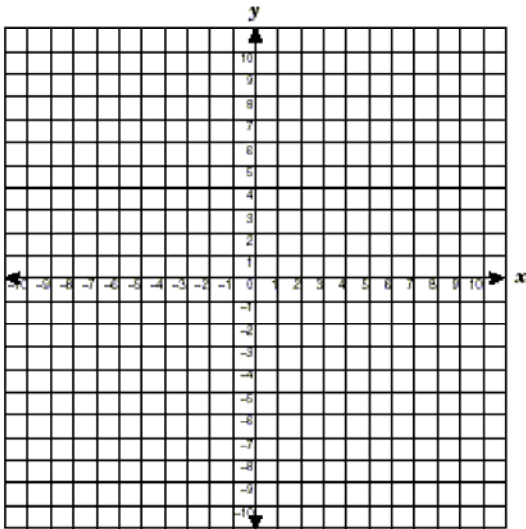

- F $f(x) = 3x - 6$
 G $f(x) = -3x + 1$
 H $f(x) = 3x + 10$
 J $f(x) = \frac{1}{3}x + 2$

- 33 A large room has the dimensions shown below. A partition is to be installed so that 2 classes can use it. The area of the smaller classroom is $38x$. How can the area of the larger classroom be expressed in terms of x ?

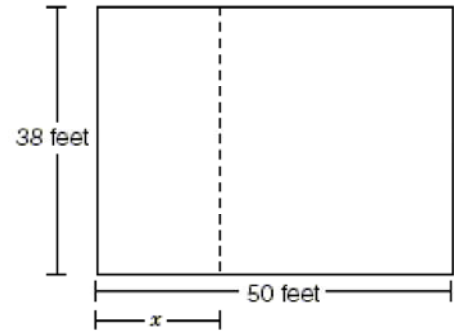

- A $38(50 - x)$
 B $\frac{(50 - x)}{38}$
 C $50 - 38x$
 D $\frac{38(50)}{3x}$

- 34 A 72-inch piece of wire was cut into equal segments, which were then soldered at the ends to form the edges of a cube.

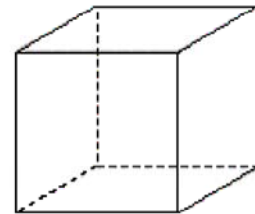

What is the volume of the cube?

- F 1728 in.^3
 G 729 in.^3
 H 216 in.^3
 J 576 in.^3

- 35 What is the area of the largest square in the diagram?

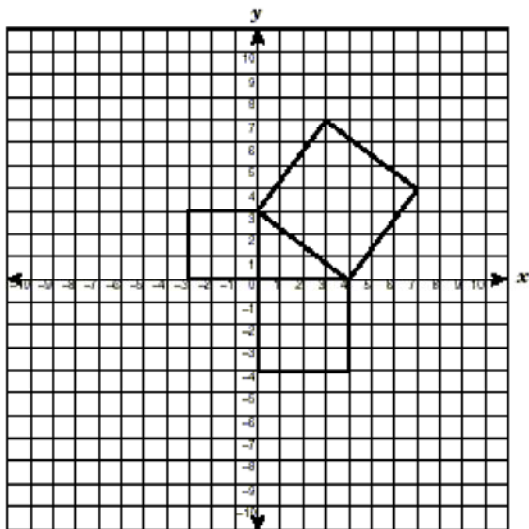

- A 25 units²
- B 9 units²
- C 5 units²
- D 16 units²

- 36 The net of a cube is shown below.

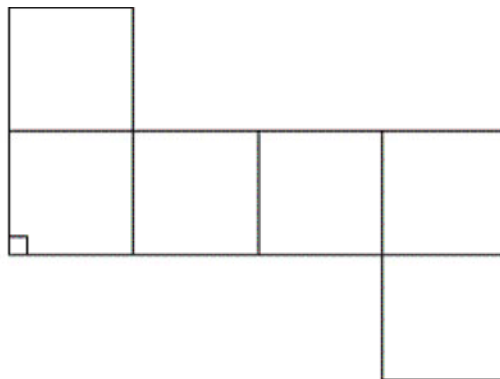

Use the ruler on the Mathematics Chart to measure the dimensions of the cube to the nearest tenth of a centimeter. Which best represents the volume of this cube to the nearest cubic centimeter?

- F 11 cm³
 - G 30 cm³
 - H 13 cm³
 - J 42 cm³
- 37 At Reyna High School 50% of the students eat lunch in the school cafeteria. In the same school 10% of the students participate in sports. What is the probability that a student selected at random eats in the school cafeteria and participates in sports?

- A $\frac{1}{10}$
- B $\frac{1}{60}$
- C $\frac{1}{2}$
- D $\frac{1}{20}$

38 Monica collected data on the ages and heights of a random sample of sixth-, seventh-, and eighth-grade students at her school. If she plots the data on a scatterplot, what relationship will she most likely see between age and height?

- F No correlation
- G A positive correlation
- H A negative correlation
- J A constant correlation

39 The pentagon in the graph below is to be dilated by a scale factor of $\frac{1}{3}$.

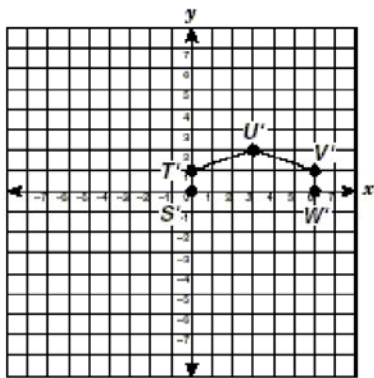
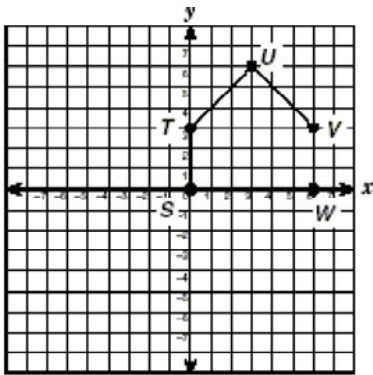

A

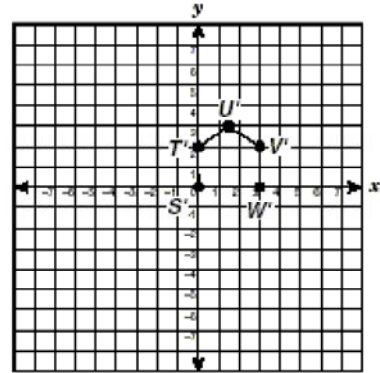

B

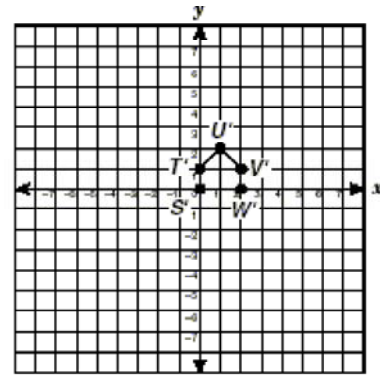

C

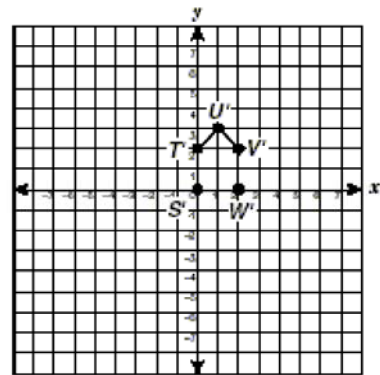

D

- 40 In the distance formula $d = rt$, r represents the rate of change, or slope. Which ray on the graph best represents a slope of 55 mph?

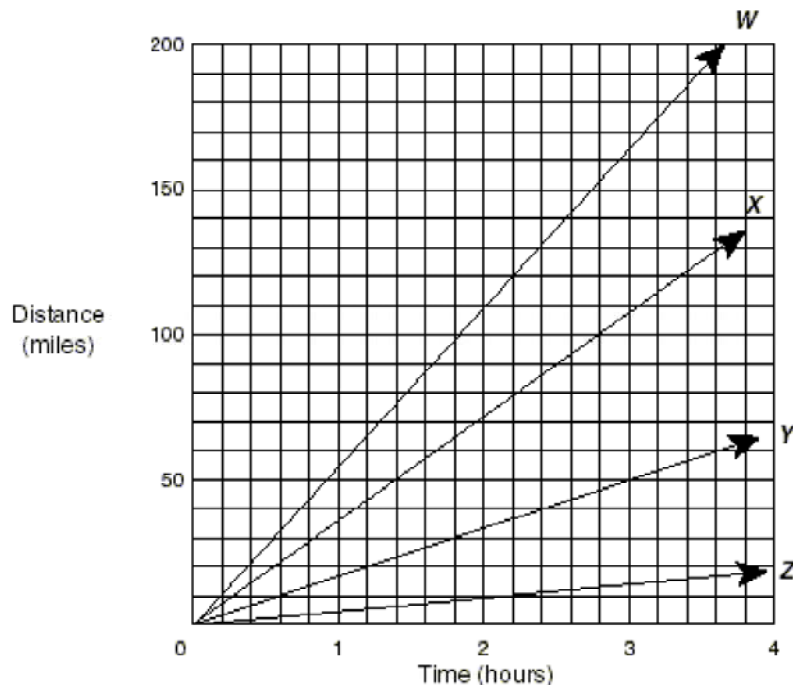

- F X
 G W
 H Z
 J Y
- 41 The function $g(x) = 1.25 + 0.70(x - 1)$ represents the charge for parking in the mall garage for x number of hours. Which statement best represents the formula for this charge?
- A The charge consists of a flat rate of \$0.70 for every hour parked.
 B The charge consists of \$1.25 for every hour parked plus a set fee of \$0.70.
 C The charge consists of \$1.25 for the first hour parked and \$0.70 for each additional hour.
 D The charge consists of a set fee of \$1.25 plus \$0.70 for every hour parked.

- 42 Mr. McGregor wanted to cover the floor in his living room with carpet that cost \$12 per square yard. The blueprint below shows the area of the living room relative to the area of the house.

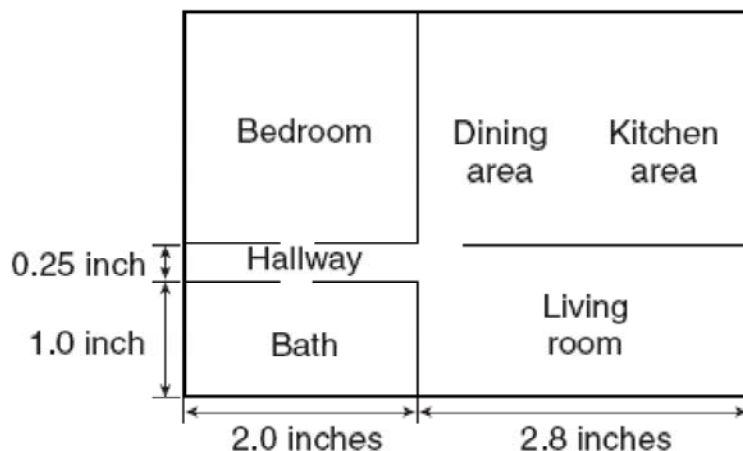

What information must be provided in order to find the total cost of the carpet?

- F** The scale of yards to inches in the blueprint
G The lengths and widths of the adjoining rooms in the blueprint
H The total area of the house in the blueprint
J The thickness of the carpeting in inches
- 43 The cost of renting a DVD at a certain store is described by the function $f(x) = 4x + 3$ in which $f(x)$ is the cost and x is the time in days. If Lupe has \$12 to spend, what is the maximum number of days that she can rent a single DVD if tax is not considered?
- A** 3
B 7
C 2
D 1
- 44 In the graph of the function $y = x^2 + 5$, which describes the shift in the vertex of the parabola if, in the function, 5 is changed to -2 ?
- F** 3 units down
G 3 units up
H 7 units down
J 7 units up
- 45 If the variables x and y are related so that $x - y > x + y$, which statement must be true?
- A** The variable y is a negative number.
B The variable y is a positive number.
C The variable x is a negative number.
D The variable x is greater than the variable y .

46 Which of the equations below represents the second step of the solution process?

Step 1. $5(6x + 4) + 1 = -39$

Step 2.

Step 3. $30x + 21 = -39$

Step 4. $30x = -60$

Step 5. $x = -2$

F $30x + 4 + 1 = -39$

G $30x + 20 + 1 = -39$

H $5(6x + 1) + 4 = -39$

J $5(6x + 5) = -39$

47 The area of a rectangle is given by the equation $2l^2 - 5l = 18$, in which l is the rectangle's length. What is the length of the rectangle?

A 6

B 2

C 1.5

D 4.5

48 Which is the best representation of the function $y = x$?

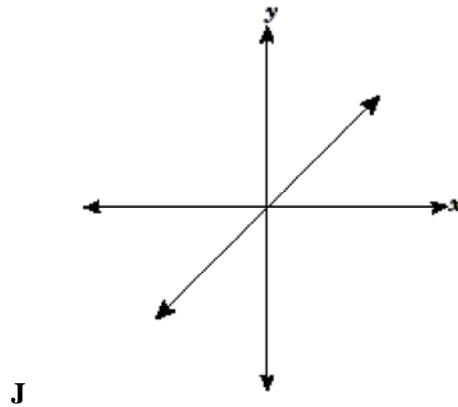
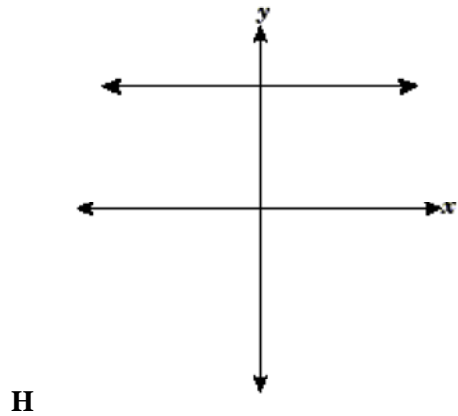
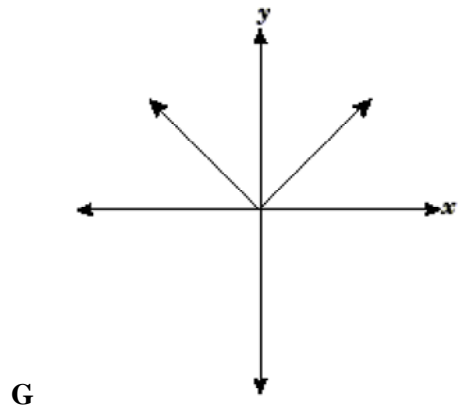
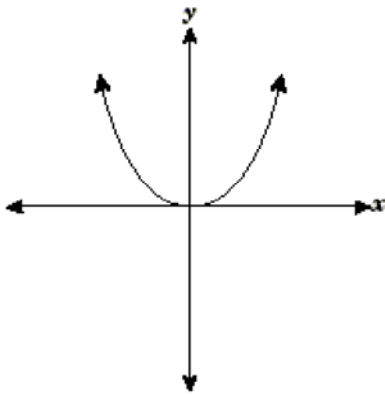

49 Passengers on many commercial flights may make calls from a telephone provided by the airline. On a certain airline a call costs \$3 to connect plus \$2 for each minute. Which equation best represents c , the total cost for a call that lasts m minutes?

- A $c = 3 + 2m$
- B $m = 3 + 2c$
- C $c = 2 + 3m$
- D $m = 2 + 3c$

50 Which histogram best reflects the data shown in the table?

U.S. Household Income	
Income Range	Frequency
Under \$10,000	
\$10,000–24,999	
\$25,000–49,999	
\$50,000–74,999	
\$75,000–99,999	
Total	100 Households

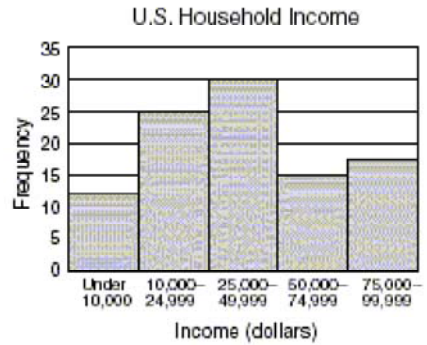

F

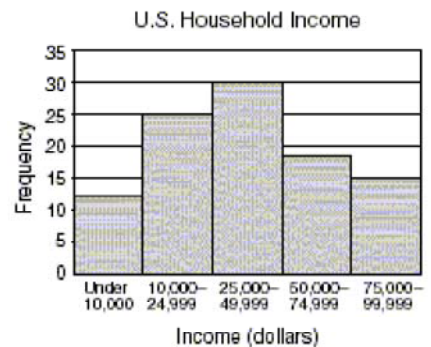

G

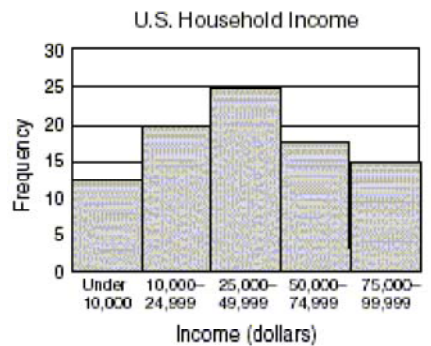

H

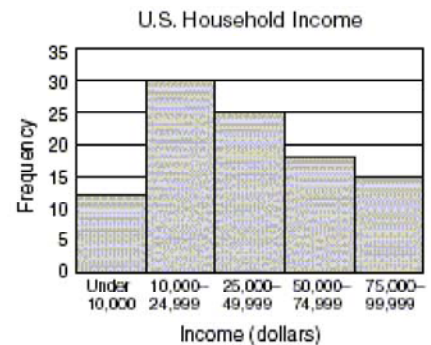

J

- 51 Students in a science class recorded lengths of a stretched spring, as shown in the table below.

Distance Stretched, x (centimeters)	Weight, y (newtons)
0	0
2	10
4	20
7	35
9	45
10	50

Which equation best represents the relationship between distance stretched, x , and the weight on the spring, y ?

- A $y = \frac{5}{x}$
- B $y = 5x^2$
- C $y = -5x$
- D $y = 5x$
- 52 The Alejo family budgeted \$2000 for their vacation. Their budget consisted of \$800 for travel costs and \$75 per day for other expenses. Which inequality represents the number of days, x , the family could have stayed on vacation?
- F $800 + 75x \leq 2000$
- G $800x - 75 \geq 2000$
- H $800x + 75 \geq 2000$
- J $800 - 75x \leq 2000$